



MODEL B[®] with CSR

CONTROLLED SCREEN RETURN

Spring Roller-Type Screen

DA-LITE SCREEN COMPANY, INC.
 3100 North Detroit Street
 Post Office Box 137
 Warsaw, Indiana 46581-0137
 Phone: 574/267-8101
 800-622-3737
 Fax: 574/267-7804
 http://www.da-lite.com
 e-mail: info@da-lite.com

SPECIFICATION DATA

SUGGESTED SPECIFICATIONS: _____ projection screens, _____ (H) x _____ (W), wall or ceiling mounting type. Screen to have a heavy 22-gauge octagonal steel case with flat back design with baked enamel finish and fitted with end caps concealing roller ends with integral bearing surface to support roller and integral brackets for wall mounting by means of slotted screw holes and ceiling mounting by means of powder coated hanger rings. To be equipped with Controlled Screen Return (CSR) to control the return speed of the screen into the case. Bottom of fabric shall be mounted into a metal strip in a tubular steel slat finished in baked enamel. Ends of slat shall be protected by plastic caps. Plated steel slat pull shall be attached to slat with screws. To have Matte White, Glass Beaded, High Power, Video Spectra[®] 1.5 or High Contrast Matte White surface with masking borders standard on flame retardant and mildew resistant seamless fabric. Fabric shall be mounted into a metal strip in a metal Camlok roller system without tape, glue, staples or cords so that fabric may be easily replaced yet cannot be pulled from roller.

Matte White, Glass Beaded, Video Spectra[®] 1.5 and High Contrast Matte White: Surfaces will be seamless.

High Power: Horizontal seam required when both dimensions exceed 6'.

DIMENSIONS

Sizes		A - Overall Case Length		B - Distance Between Hangers		C - Brackets		D - Case Diameter (Width)		Shipping Weight	
H x W	Cm	In.	Cm	In.	Cm	In.	Cm	In.	Cm	Lbs.	Kg
70" x 70"	178 x 178	73-3/8"	186	72-5/8"	184	3-5/8"	9.2	2-3/4"	7	19	8.62
64" x 84"	160 x 213	87-3/8"	222	86-5/8"	220	3-5/8"	9.2	2-3/4"	7	26	11.79
84" x 84"	213 x 213	87-3/8"	222	86-5/8"	220	3-5/8"	9.2	2-3/4"	7	28	12.70
72" x 96"	183 x 244	99-3/8"	252	98-5/8"	251	3-5/8"	9.2	2-3/4"	7	30	13.61
96" x 96"	244 x 244	99-3/8"	252	98-5/8"	251	3-5/8"	9.2	2-3/4"	7	32	14.52

VIDEO FORMAT DIMENSIONS

Viewing Area		Nominal Diagonal Size		A - Overall Case Length		B - Distance Between Hangers		C - Brackets		D - Case Diameter (Width)		Shipping Weight	
H x W	Cm	In.	Cm	In.	Cm	In.	Cm	In.	Cm	In.	Cm	Lbs.	Kg
50" x 67"	127 x 170	84"	213	73-3/8"	186	72-5/8"	184	3-3/8"	8.6	2-1/2"	6	17	7.71
57" x 77"	145 x 196	96"	244	84-3/8"	214	83-5/8"	212	3-5/8"	9.2	2-3/4"	7	25	11.34
60" x 80"	152 x 203	100"	254	87-3/8"	222	86-5/8"	220	3-5/8"	9.2	2-3/4"	7	26	11.79
69" x 92"	175 x 234	120"	305	99-3/8"	252	98-5/8"	251	3-5/8"	9.2	2-3/4"	7	29	13.15

HDTV FORMAT DIMENSIONS

Viewing Area		Nominal Diagonal Size		A - Overall Case Length		B - Distance Between Hangers		C - Brackets		D - Case Diameter (Width)		Shipping Weight	
H x W	Cm	In.	Cm	In.	Cm	In.	Cm	In.	Cm	In.	Cm	Lbs.	Kg
45" x 80"	114 x 203	29"	234	87-3/8"	222	86-5/8"	220	3-5/8"	9.2	2-3/4"	7	25	11.34
52" x 92"	132 x 234	106"	269	99-3/8"	252	98-5/8"	251	3-5/8"	9.2	2-3/4"	7	28	12.70

Specifications subject to change without notice.
 Hanger rings add 3/4" to the overall dimension C.

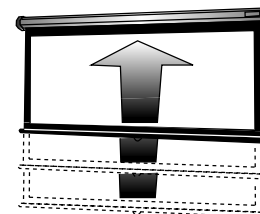

WHEN ORDERING, MARK APPROPRIATE SELECTIONS:

Select size from charts above.

Select viewing surface:

- Matte White
- Glass Beaded
- Video Spectra[®] 1.5
- High Power
- High Contrast Matte White

Optional Accessories:

(Select):

- No. 6 Wall Bracket – 6" non-adjustable extension brackets.
- No. 11 Wall Bracket – 10" or 14" non-adjustable extension brackets.
- No. 23 Adjustable Wall Bracket – 10", 14", 15-3/4", 18-1/4", 20", or 24" adjustable extension brackets.
- Tilt-Lock for Keystone Elimination (used with extension brackets).
- T-Bar Scissors Clip for drop ceilings (black or white).
- Pull Rod.
- No borders (Black masking borders standard).
- Articulating Arm for 60" and 70" screens.

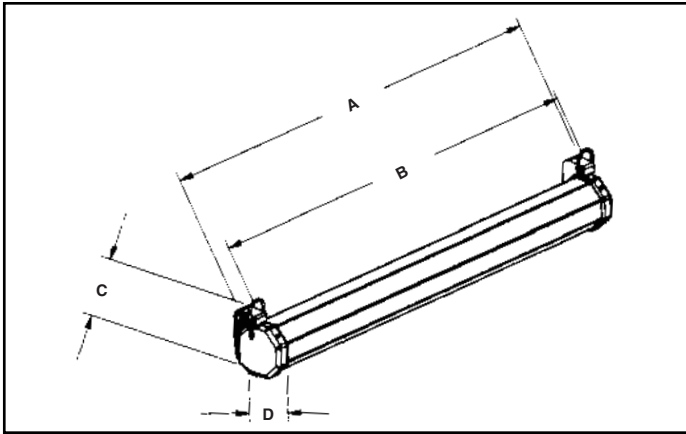

Project: _____

Architect: _____

Phone: _____

Contractor: _____

Phone: _____

Supervisor: _____

Phone: _____

Date: _____

Revised: _____

MODEL B® WITH CSR

OPTIONAL ACCESSORIES

OPTIONAL ACCESSORIES: to provide chalkboard clearance: Furnish 6" heavy gauge extension wall brackets to mount screen. To provide for keystone elimination: Furnish #11 or #23 adjustable extension wall brackets. Furnish magnetic tilt lock for keystone elimination.

NOTE: Brackets also are used for mounting screen across a corner.

EXTENSION WALL BRACKETS

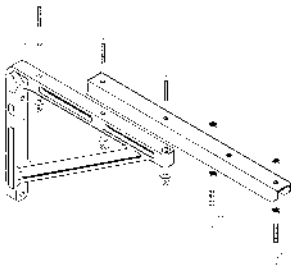

No. 23 ADJUSTABLE WALL BRACKET

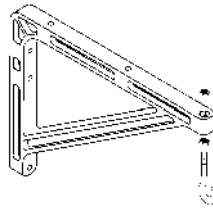

No. 11 WALL BRACKET
Non-adjustable. Permits screen to extend 10" or 14" from wall.

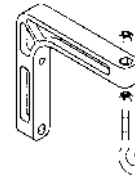

No. 6 WALL BRACKET
Non-adjustable. Permits screen to extend 6" from wall.

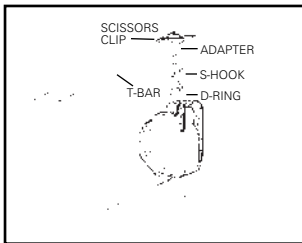

T-BAR SCISSORS CLIP

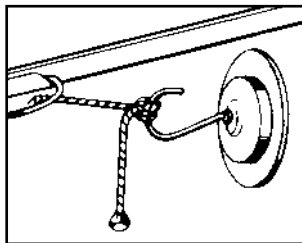

TILT LOCK for Keystone elimination. Used with extension brackets or T-Bar Scissor Clips.

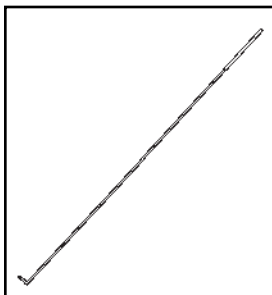

PULL ROD
Zinc plated rod with black plastic handle grip allows easy access to screen when mounted out of reach. Also can be used as a pointer.



ARTICULATING KEYSTONE ELIMINATOR
Allows screen to be moved from a right to left direction for any audience seating arrangement, while also allowing screen to be tilted backward to eliminate keystone (available for 60" and 70").